



A Series Piston Accumulators

250 & 350 bar accumulators with fluid volumes from 0.1 litres to 76 litres

*Catalogue HY07-1240/UK
October 2004*



Contents	Page
Accumulator Selection	2
Certification	2
Specification	3
Features and Benefits	4
Capacities and Dimensions	5
Ports	6
Operating Temperatures	6
Seals and Fluid Media	6
Options and Spare Parts	7
Accumulator Sizing	8
Accessories	10
How to Order	11

Accumulator Selection

Parker offers a comprehensive range of CE-approved piston and bladder accumulators to suit different application and performance criteria.

A Series piston accumulators, described in this catalogue, are designed for industrial and mobile applications where piston speeds and flow rates are relatively low, such as in suspension systems, power units and pressure maintenance.

AP Series piston accumulators are high performance accumulators designed for demanding industrial applications such as die-casting and plastic injection moulding, where high flow rates and piston speeds up to 8m/s are routinely demanded. AP Series accumulators are described in catalogue HY07-1247.

BAE Series bladder accumulators For applications where fast response times, a higher tolerance of fluid contamination and an instantaneous failure mode are required, the BAE Series of bladder accumulators is available – see catalogue HY07-1235.

When selecting an accumulator, factors to be considered should include the following:

- appropriate certification for the country of final destination
- maximum working pressure
- fluid capacity
- gas capacity
- flow rate, port type and size
- mounting space and orientation

Guidance regarding the selection of a piston or bladder accumulator is provided in Parker bulletin HY07-1243, 'Making the Choice'.

In addition, the type of gas valve and its connection and the requirement for a charging and gauging kit should also be considered. In certain industrial applications, the use of a safety shut-off valve or 'safety block' is mandatory, and a suitable valve should be incorporated into the system design. Parker offers a range of safety blocks for this purpose – see catalogue HY07-1241.

Certification

Accumulators are pressure vessels which are subject to the safety laws and regulations of the country in which they are operated. In addition, other industry-specific regulations may apply in applications such as shipbuilding, aviation etc.

Prior to the adoption of the Europe-wide CE approval for pressure vessels in 2002, many European member states operated their own approvals systems, eg: TÜV in Germany, DRIRE in France, ISPEL in Italy etc. Following the introduction of the Pressure Equipment Directive (97/23/EC), users of accumulators can opt for CE approval in place of existing national standards. CE approval incorporates the requirements of all existing national approvals, enabling an approved pressure vessel to be used in any European Union member state without the need for local approval.

Mounting

The wide variety of lengths and bore sizes available within Parker's piston accumulator range makes this design particularly suitable for applications where mounting space is critical. The same fluid capacity can be achieved from different configurations of bore and overall length, providing exceptional versatility for the designer. While the optimum mounting orientation is vertical, angled and horizontal mountings are permissible if the hydraulic fluid is kept clean; high levels of contaminants in the fluid can result in uneven or accelerated seal wear.

Special Designs

For applications where a standard accumulator is not suitable, our engineers will be pleased to discuss custom designs to suit your application.

Industry-Leading Systems Capability

Parker's comprehensive range of pumps, valves, hoses and filtration products enables you to design and build a complete hydraulic system with proven, 100% compatible parts. With value-adding services which extend from design to commissioning and in-service support, you can be confident that Parker is the right partner for your motion and control application.

Specification

250 and 350 Bar Pressure Ranges

A Series accumulators are available to suit maximum working pressures of 250 and 350 bar. The same premium quality design and technical features guarantee optimum performance and service life from every model, while differing wall thicknesses to suit 250 or 350 bar working pressures allow the designer to specify precisely the right performance envelope for the application.

Specification

Max. working pressures	250 and 350 bar
Bore sizes (nominal):	
250 bar range	50, 75, 100, 125, 150, 200mm
350 bar range	50, 75, 100, 150mm
Working temp. range	shell: -20 to +150°C (CE approved) seals: see page 6 (other temperatures – consult factory)
Fluid volumes	0.1–76 litres
Max. piston speed	4m/s
Port style	BSPP (standard – others on request)
Gas valve	350 bar rated cored type
Approval	CE (standard – others on request)

Materials

- Shell – high strength steel
- End caps – steel
- Pistons – lightweight aluminium alloy
- Piston and end cap seals – NBR (standard): other compounds to suit application
- Piston seal backup washers – PTFE
- Piston bearing rings – PTFE
- Gas valve assembly – stainless steel
- Gas valve protector – steel
- Paint finish – black primer (standard – others on request)

Custom Designs

For unique applications and hostile environments, different designs, materials and coatings can be supplied. Please contact our engineering department to discuss custom solutions to individual application requirements.

Actual Bore Sizes and Theoretical Maximum Flow Rates

Model	Pressure	Nominal Bore Dia.	Actual Bore Dia.	Recommended Max. Flow – lpm
A2	250/350	50	51.4	380
A3	250/350	75	76.2	825
A4	250/350	100	102.4	1500
A5	250	125	127.0	2200
A6	250/350	150	146.9	3100
A8	250	200	200.0	5700

All dimensions are in millimetres unless otherwise stated.

Piston Accumulators A Series

Available Options

A wide variety of options is available for A Series accumulators, including:

- Threaded and manifold port styles and sizes
- Seal compounds
- Metric and inch mounting styles
- High flow gas ports for use with remote gas storage bottles
- Water service versions
- Gas valves
- Safety fuses
- Accumulator mounting systems
- Precharge monitors and piston position sensors
- Certifications to suit different market requirements

Filtration

For maximum component life, the system should be protected from contamination by effective filtration. Fluid cleanliness should be in accordance with ISO 4406. The quality of filters should be in accordance with the appropriate ISO standards.

The rating of the filter media depends on the system components and the application. The minimum required for hydraulic systems should be class 19/15 to ISO 4406, which equates to 25µ (β10≥75) to ISO 4572.

Safety

Charging must be carried out by qualified personnel.

Before taking any readings or pressurizing with nitrogen, the accumulator **must** be isolated from the hydraulic system and the fluid side discharged in order to depressurize it. Use only nitrogen (N₂) to pressurize the accumulator.

Danger of Explosion – Never Charge with Oxygen

The types of nitrogen permitted are: type S (99.8% pure); type R (99.99% pure); type U (99.993% pure).

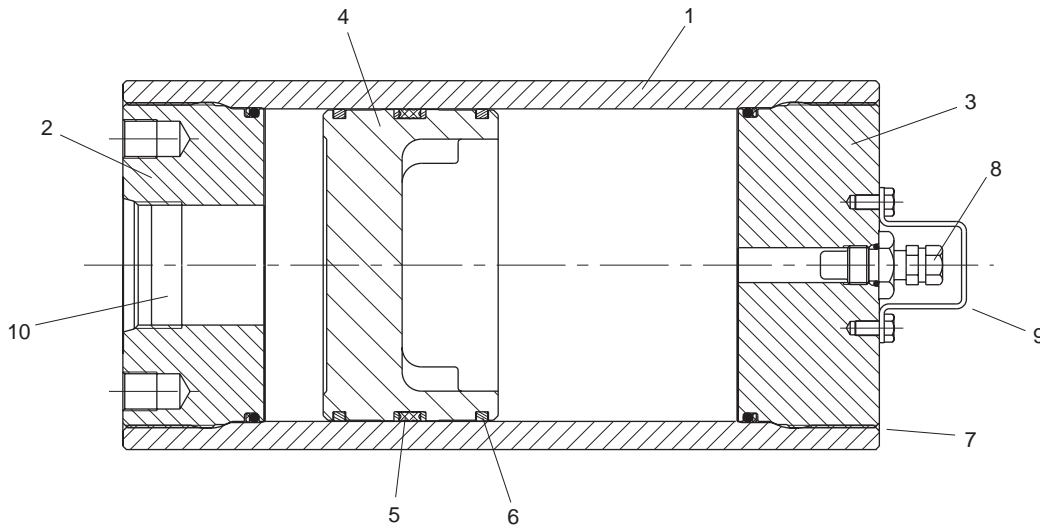

1, 2 & 3 Shell and Caps

Effective heat dissipation is vital for long seal life. Compact, rugged steel shell and end caps allow heat to dissipate efficiently, while the bore of the accumulator is micro-finished to maximise seal life. Downtime is minimised by the use of threaded caps to simplify maintenance of the accumulator, permitting quick and easy installation of seals.

4 Piston

Rapid response in high cycling applications is assured by Parker's lightweight piston design. The dished profile of the aluminium piston gives extra gas capacity while maintaining stability in the bore, and permits a greater usable volume of fluid. Piston position sensors, available as an optional feature, enable the condition of the accumulator's precharge to be monitored.

5 Piston Sealing

Long service intervals are made possible by total separation of oil and gas, even under the most severe operating conditions. Parker's A Series accumulators feature a wide piston seal assembly comprising a unique five-bladed V-profile O-ring with back-up washers, which eliminates seal roll-over even in high speed applications. The V-O-ring holds full pressure throughout long idle periods between cycles, providing dependable, full pressure storage of hydraulic energy.

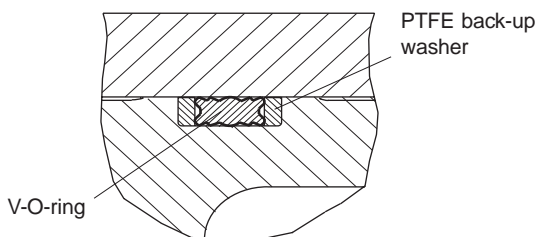

6 PTFE Bearing Rings

To reduce wear and extend service life, carbon-filled PTFE bearing rings are fitted, eliminating metal-to-metal contact between the piston and bore.

7 Safety Bleed Grooves

A bleed groove in the gas cap progressively releases unrelieved gas pressure in the accumulator as the gas cap is unscrewed.

Note: to avoid the risk of damage or injury, an accumulator must always be discharged before disassembly.

8 Gas Valve

To avoid the risk of damage or injury, an accumulator **must** be discharged before disassembling. For added safety, the gas valves fitted by Parker vent progressively as they are unscrewed. A robust, cored-type gas valve rated at 350 bar is fitted as standard to all A Series piston accumulators. A mechanically opened and closed poppet-type gas valve cartridge, also rated at 350 bar, is available as an option.

9 Gas Valve Protector

To prevent accidental – and potentially hazardous – damage to the gas valve, the steel gas valve protector reduces the risk to the valve from external impact.

10 Ports

To provide the required flow rate and simplify system design, a wide range of port types and sizes is available. BSPP ports are supplied as standard; ISO, metric and SAE threaded and metric flanged ports to ISO 6162 are available to special order.

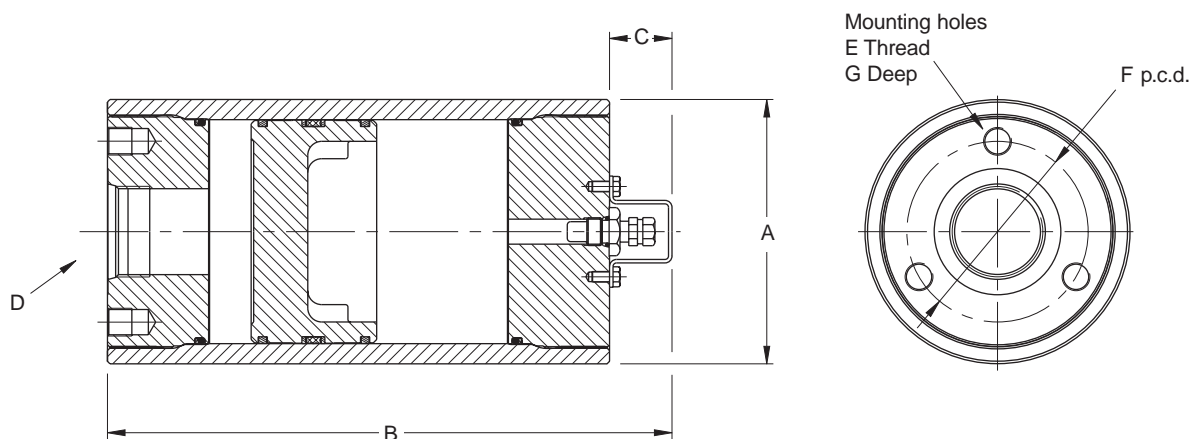

250 and 350 Bar Models, Capacities and Dimensions

Model	Code	Bore Ø	Fluid Volume Litres	Gas Volume Litres	250 Bar			350 Bar			C	E ²	F	G	250 Bar	350 Bar	
					A	B	D BSPP	A	B	D BSPP					Weight kg	Weight kg	
A2	0005	51.4	0.1	0.1	61	172	G ^{3/4}	64	172	G ^{3/4}	27 ¹	-	-	-	1.8	2.7	
	0010		0.15	0.2		211			211						2.0	3.0	
	0015		0.25	0.25		250			250						2.5	3.3	
	0029		0.5	0.5		360			360						3.0	4.3	
	0058		1.0	1.0		590			590						4.4	6.2	
A3	0029	76.2	0.5	0.55	91	260	G ^{3/4}	96	260	G ^{3/4}	29 ¹	M10	60	15	9.0	9.0	
	0058		1.0	1.0		364			364						11	11	
	0090		1.5	1.5		481			481						13	13	
	0116		2.0	2.0		573			573						14	15	
	0183		3.0	3.0		814			814						16	20	
A4	0058	102.4	1.0	1.1	121	295	G1	127	306	G1	29 ¹	M12	82	18	15	18	
	0116		2.0	2.0		411			422						18	22	
	0231		3.8	4.0		640			651						23	30	
	0347		5.7	5.9		872			883						29	38	
	0578		9.5	9.6		1330			1341						41	54	
A5	0058	127.0	1.0	1.3	153	272	G1	-	-	-	29 ¹	M12	100	18	22	-	
	0116		2.0	2.2		346									-	26	-
	0231		3.8	4.1		496									-	32	-
	0347		5.7	6.0		645									-	39	-
	0578		9.5	9.8		943									-	52	-
A6	0231	146.9	3.8	4.3	175	442	G1 ^{1/2}	180	487	G1	29 ¹	M12	110	18	35	53	
	0347		5.7	6.2		554			600						42	60	
	0578		9.5	10.0		778			824						54	74	
	0924		15	15.7		1113			1159						73	96	
	1155		19	19.4		1337			1383						85	110	
	1733		28.5	28.9		1896			1941						112	148	
	2310		38	38.4		2454			2500						147	183	
A8	0578	200.0	9.5	10.7	230	629	G2	-	-	-	42	M16	170	24	98	-	
	1155		19	20.2		931									-	122	-
	1733		28.5	29.7		1232									-	146	-
	2310		38	39.1		1532									-	170	-
	2772		45	46.2		1774									-	189	-
	2888		47	48.2		1834									-	194	-
	3465		57	58.0		2136									-	217	-
	4620		76	77.2		2738									-	266	-

All dimensions are in millimetres unless otherwise stated.

Notes to Tables

- ¹ Where the optional poppet-type gas valve is fitted (see page 7), dimension C should be increased by 13mm.
- ² A Series piston accumulators are supplied as standard with the metric threaded mounting holes shown in the table. They are also available with inch pattern mounting holes, indicated by the Design Number in the model code – see page 11.

Hydraulic and Gas Ports

The ports shown on page 5 are supplied as standard at the fluid ends of A Series accumulators, and at the gas ends of these accumulators when ordered for use with gas bottles. A range of optional threaded and flanged ports is also available, as shown in the tables below. These are specified by adding the relevant code to the accumulator model number – see page 11. Note that, where the required fluid port is the standard BSPP size for the accumulator model chosen, the fluid port field in the order code should be left blank.

Optional Threaded Ports

BSPP ¹			Metric to DIN 3852-1			Metric to ISO 6149-1			SAE Thread		
Thread Size	From Model	Code	Thread Size	From Model	Code	Thread Size	From Model	Code	Thread Size	From Model	Code
G ³ / ₄	A2	RC	M14	A2	GA	M14	A2	YA	#5	A2	TA
G1	A3	RD	M18	A2	GB	M18	A2	YB	#6	A2	TB
G1 ¹ / ₄	A3	RE	M22	A2	GC	M22	A2	YC	#8	A2	TC
G1 ¹ / ₂	A4	RF	M27	A2	GD	M27	A2	YD	#10	A2	TI
G2	A4	RG	M33	A3	GE	M33	A3	YE	#12	A2	TD
-	-	-	M42	A3	GF	M42	A3	YF	#16	A3	TE
-	-	-	-	-	-	-	-	-	#20	A3	TF
-	-	-	-	-	-	-	-	-	#24	A4	TG

¹ Where the required fluid port is the standard BSPP size for the accumulator bore diameter chosen (see dimension D, page 5), the fluid port field in the order code on page 11 should be left blank.

Optional Flanged Ports

A Series accumulators are available with metric flange ports to ISO 6162, as shown in the table. Inch pattern flange ports and flange ports for higher pressure operation are also available – please consult the factory for details.

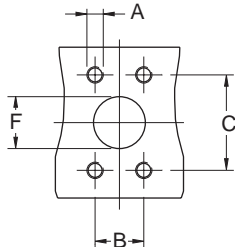

Flange Ports to ISO 6162						
Flange Size	From Model	A*	B ±0.25	C ±0.25	F	Code
DN13	A3	M8	17.5	38.1	13	MT
DN19	A3	M10	22.3	47.6	19	MU
DN25	A3	M10	26.2	52.4	25	MV
DN32	A3	M10	30.2	58.7	32	MW
DN38	A4	M12	35.7	69.9	38	MJ
DN51	A4	M12	42.9	77.8	51	ML
DN64	A6	M12	50.8	88.9	64	MM
DN76	A8	M16	61.9	106.4	76	MN

* Parker recommends that bolts with a minimum strength of ISO 898/1 grade 12.9 should be used for attaching port flanges to the accumulator.

Operating Temperatures, Seals and Fluids

A Series piston accumulators are fitted as standard with nitrile (NBR) seals. A range of alternative seal materials is available for use at higher or lower temperatures, or with synthetic or high water content fluids, as shown in the table. Other seals are also available for use in exceptional conditions – please consult the factory with details of the application.

The shells of Parker's A series accumulators are CE approved for operation at temperatures between -20°C and +150°C.

Water Service

A Series piston accumulators are available for use with water as the fluid medium. Modifications include plating of all working surfaces. Please consult the factory for details.

Seal Type	Code	Fluid Medium	Temperature Range
Nitrile (NBR)	K	General purpose, petroleum-based fluids	-30°C to +75°C
Fluorocarbon Elastomer (FPM)	E	High temperature and/or synthetic fluids	-25°C to +120°C
Ethylene Propylene (EPR)	D	Phosphate-esters	-40°C to +120°C
Hydrogenated Nitrile (HNBR)	H	Most oil-based and biodegradable fluids	-40°C to +160°C
Carboxylated Nitrile (XNBR)	J	Water glycol, high water content fluids	-30°C to +75°C
Low Temperature Nitrile (NBR)	Q	General purpose fluids at low temperatures	-45°C to +70°C

All dimensions are in millimetres unless otherwise stated.

Gas Valves

The standard gas charging valve fitted to A Series 250 and 350 bar piston accumulators is a cored-type gas valve, rated at 350 bar. A mechanically opened and closed poppet-type gas valve cartridge, also rated at 350 bar, is available as an option. Both types of charging valve may be used with the Charging and Gauging Kit illustrated on page 10.

Safety Fuses

Safety fuses are available on A Series accumulators to prevent over-pressurization of gas due to external heat or excess hydraulic pressure. They comprise a housing incorporating a disk which is calibrated to rupture at a pre-determined pressure, to be specified by the customer at the time of ordering. Please contact the factory for further information.

Piston Position Sensors

Position sensors, available as an optional feature, enable a wide range of conditions to be monitored. The design illustrated is one of several available to suit differing applications. In this design, non-contacting proximity sensors monitor the travel of a steel rod which bears against the gas side of the piston, indicating piston positions specified by the customer. The resulting signals can be used to switch pumps on or off, or to operate control valves in a pre-set sequence.

For more information, please contact our Engineering Department with details of the application.

Piston Accumulator Seal Kits

Seal kits are available for all A Series accumulator models. When ordering seal kits, please supply the complete model number from the identification plate and specify the fluid type and the temperature at which the accumulator is to be used.

Seal Kit Numbers

The seal kits listed contain items 5, 6, 7, 8, 9 and 11.

Parts List

- | | |
|------------------------------|------------------------------|
| 1 Shell | 8 O-ring |
| 2 Hydraulic cap | 9 O-ring back-up washer |
| 3 Gas cap | 10 Gas valve |
| 4 Piston | 11 Gas valve O-ring |
| 5 V-O-ring | 12 Gas valve protector |
| 6 V-O-ring back-up washers | 13 Gas valve protector screw |
| 7 PTFE bearing ring (piston) | |

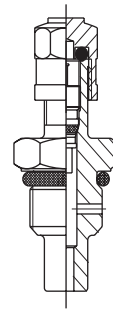

Standard Cored-Type Gas Valve

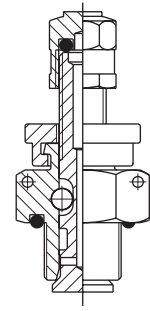

Optional Poppet-Type Gas Valve

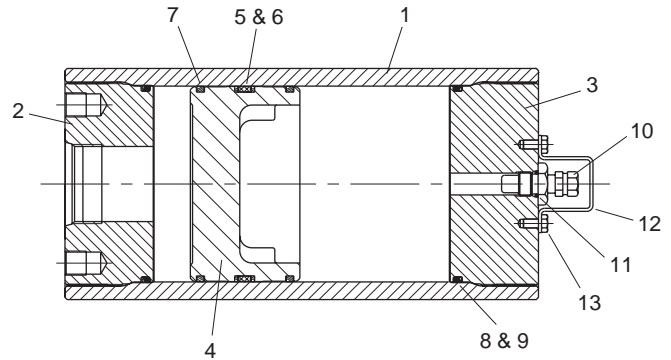
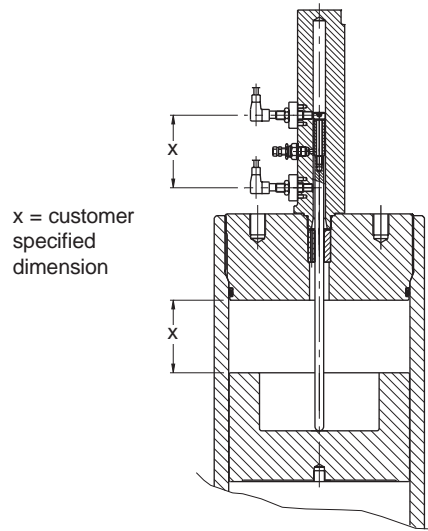

Model	Nitrile NBR	Fluorocarbon Elastomer FPM	Ethylene Propylene EPR	Hydrogenated Nitrile HNBR	Carboxilated Nitrile XNBR	Low Temp. Nitrile NBR
A2	RK0200K000	RK0200E000	RK0200D000	RK0200H000	RK0200J000	RK0200Q000
A3	RK0300K000	RK0300E000	RK0300D000	RK0300H000	RK0300J000	RK0300Q000
A4	RK0400K000	RK0400E000	RK0400D000	RK0400H000	RK0400J000	RK0400Q000
A5	RK0500K000	RK0500E000	RK0500D000	RK0500H000	RK0500J000	RK0500Q000
A6	RK0600K000	RK0600E000	RK0600D000	RK0600H000	RK0600J000	RK0600Q000
A8	RK0800K000	RK0800E000	RK0800D000	RK0800H000	RK0800J000	RK0800Q000

Calculating Accumulator Size

Accurate calculation of accumulator size requires many factors to be considered – the working volume of fluid, ambient and maximum operating temperatures, the working pressure range etc. In addition, correction factors must be applied to allow for temperature compensation between the ambient and gas temperatures, and the consequent effect on precharge pressure in the accumulator. Where the working cycle is sufficiently rapid that no heat transfer takes place, the process is termed *adiabatic*. Conversely, where the process takes place at a constant temperature, it is termed *isothermal*.

Accumulator Sizing Charts

The charts shown opposite are used to estimate the size of piston accumulator required to provide a given volume of fluid discharge from the accumulator.

The curves are based on the following formula:

$$\Delta V = \frac{0.855 V_o [(P_2/P_1)^{1/n} - 1]}{(P_2/P_1)^{1/f}}$$

where:

ΔV = volume of fluid discharged

V_o = Accumulator size

f = charge coefficient

n = discharge coefficient

P_2 = maximum system pressure

P_1 = minimum system pressure

It is assumed that the gas precharge pressure = 0.9 P_1

Isothermal and Adiabatic Operation

In constructing the curves, the following factors have been assumed.

For isothermal operation eg: slow charge and discharge time, f and $n = 1$

For adiabatic operation, eg: fast charge and discharge time, f and $n = 1.8$

Note: The charts provide an estimate of the volume of accumulator required to store and release a given volume of fluid under specified conditions. In practice, the true charge and discharge coefficients will depend on the application, and may cause significant variations from the chart results. If in doubt, please contact our engineering department for a more detailed calculation.

Where the ratio P_2/P_1 exceeds 1.9, a fatigue analysis is necessary. Please contact our engineering department for further information.

How to Use the Sizing Chart

These charts are used to find accumulator size V_o when the required output ΔV is known.

Example

Refer to the red lines in the charts opposite.

$\Delta V = 6$ litres

$P_2 = 170$ bar

$P_1 = 100$ bar

Step 1

As the accumulator output ΔV is known, choose the appropriate pair of charts from the two sets shown opposite. For outputs up to 50 litres use charts A and B, and for outputs above 50 litres use charts C and D. In this case, as the required output is 6 litres, charts A and B should be used.

Step 2

Calculate P_2/P_1 by dividing the maximum system pressure by the minimum pressure required to make the machine function. In this case, $170/100 = 1.7$

Step 3

Using chart A, locate 1.7 on the X-axis and draw a vertical line to the top of the chart.

Step 4

Depending on the cycle time, select the appropriate curve on chart A. For fast cycle times, use the adiabatic curve; for slow cycle times, the isothermal curve should be used. In this case, use the adiabatic curve. (n and $f = 1.8$)

Step 5

On chart A, identify the point at which the vertical line drawn in step 3 crosses the chosen curve (in this case adiabatic) and draw a horizontal line across to the right hand end of chart B.

Step 6

Using the lower X-axis on chart B, locate the required accumulator output (ΔV), in this case 6 litres. Draw a vertical line to the top of the chart.

Step 7

Locate the point where the vertical line drawn in step 6 crosses the horizontal line drawn in step 5. Locate the first curve to the right of this intersection.

Step 8

Follow the curve selected in step 7 up to the top X-axis (V_o) and read off the required accumulator size, in this case 30 litres. Always round up to the next largest size available; for this example, therefore, a 38 litres accumulator should be selected.

Summary

Pre-charge	90% of 100 bar = 90 bar
Adiabatic / Isothermal	Adiabatic
Accumulator selected	A6ES2310L2K

Accumulator Sizing Chart $\Delta V = 0.1$ to 50 Litres Chart A

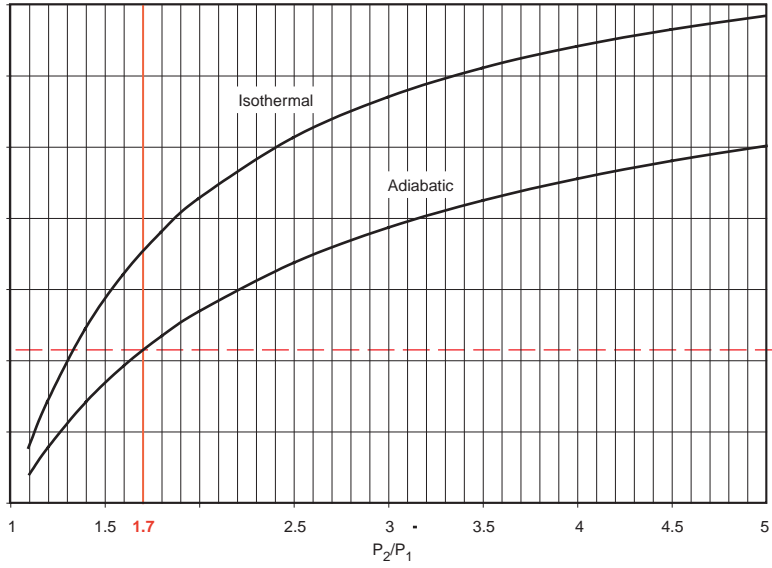
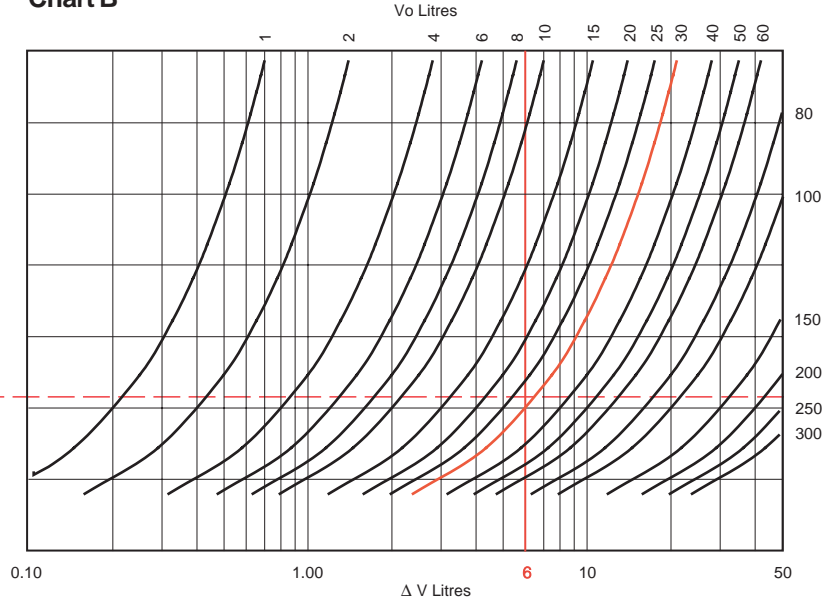

Chart B



Accumulator Sizing Chart $\Delta V = 10$ to 200 Litres Chart C

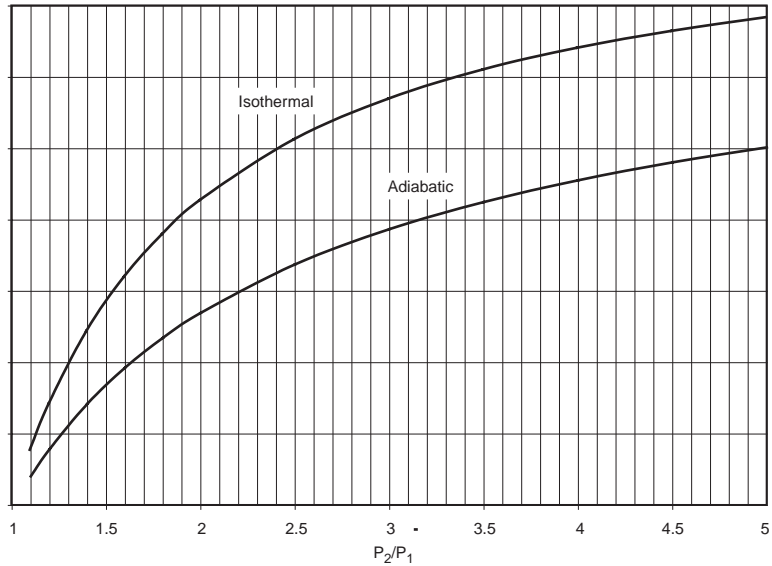
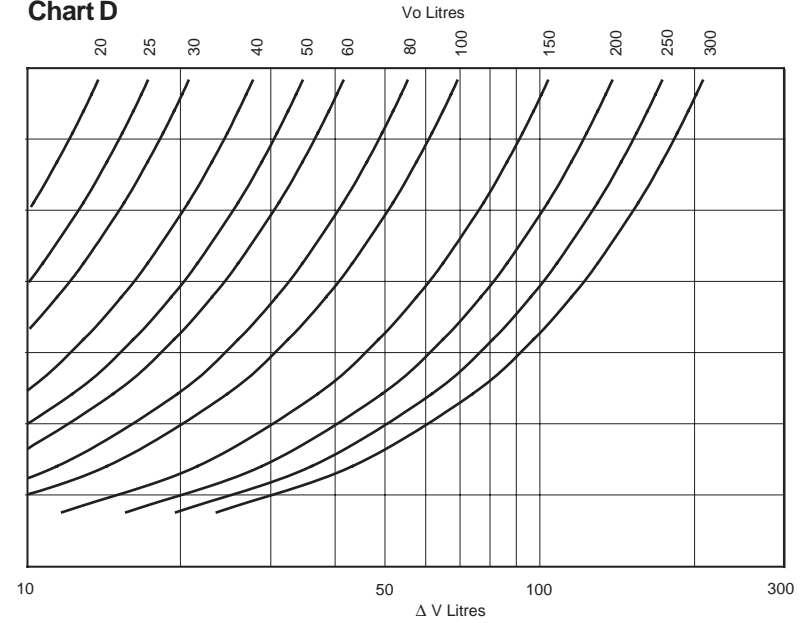
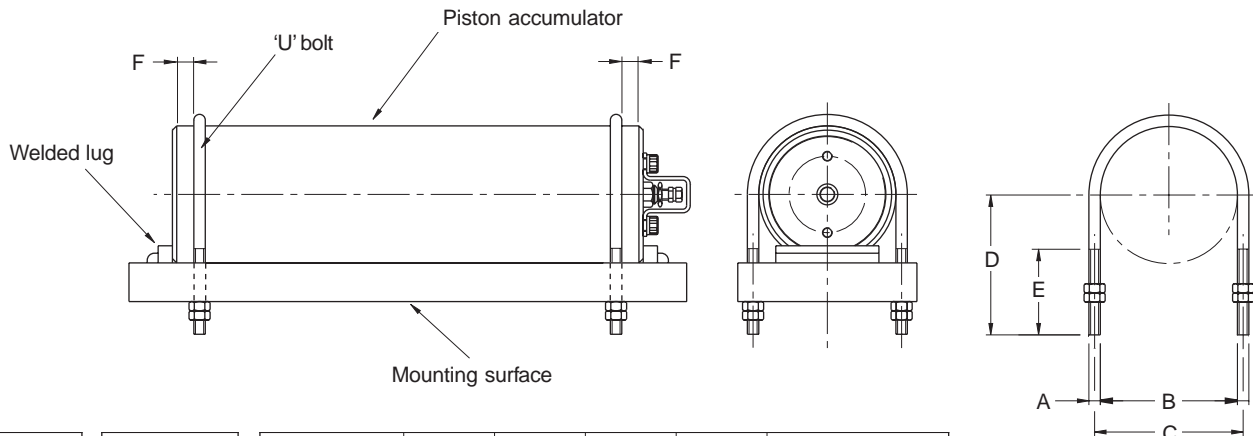

Chart D



'U' Bolts for Piston Accumulators



Model	Part No.	A	B	C	D	E	F	
							Min	Max
A2	PE1093-4	M6 x 1	62	68	70	45	10	25
A3	PE1093-1	M8 x 1.25	96	104	92	60	10	25
A4	PE1093-2	M12 x 1.75	128	140	114	76	10	30
A5	PE1093-12	M12 x 1.75	158	170	140	76	15	40
A6	PE1093-3	M16 x 2	180	196	155	95	20	45
A8	PE1093-13	M16 x 2	234	250	200	95	20	50

Note: 'U' bolts should be mounted within the distances shown from the end of the accumulator, to avoid deformation of the shell.

Charging and Gauging

The charging and gauging assemblies listed in the table are suitable for use with both the standard cored-type gas valve and the optional poppet type. Each kit contains a UCA assembly incorporating a gas valve, bleed valve and gas chuck, and a 3m long charging hose with standard nitrogen bottle fittings. The kit includes 25 bar and 250 bar pressure gauges, to permit easy monitoring of the gas precharge. Full details for use of the charging and gauging kit are given in Bulletin HY07-1244-T.

Territory	Gas Bottle Fitting	Part No.
UK	5/8 BSP (male)	UCA 02
France	W 21.7 x 1/14" (female)	UCA 04
Germany	W 24.32 x 1/14" (female)	UCA 01
Italy	W 21.7 x 1/14" (male)	UCA 05
US	0.960 x 1/14" (male)	UCA 03

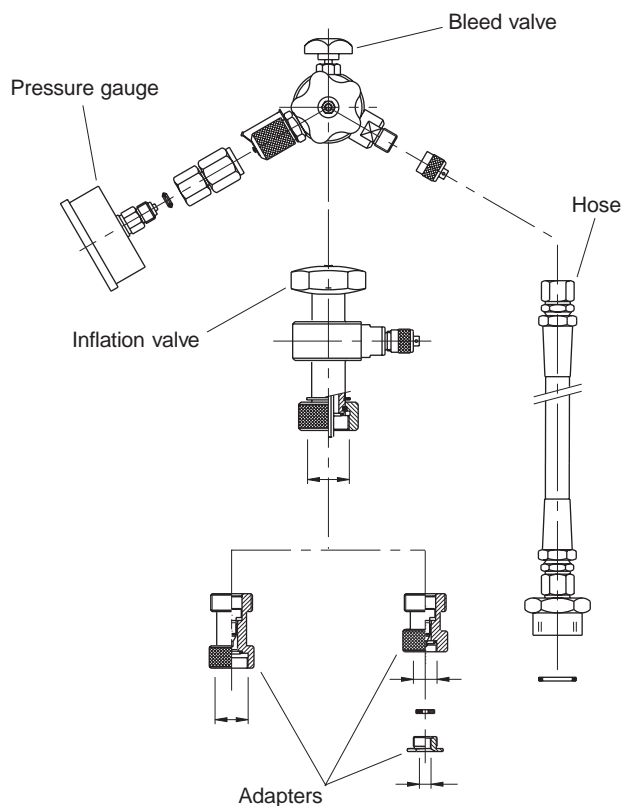

All dimensions are in millimetres unless otherwise stated.

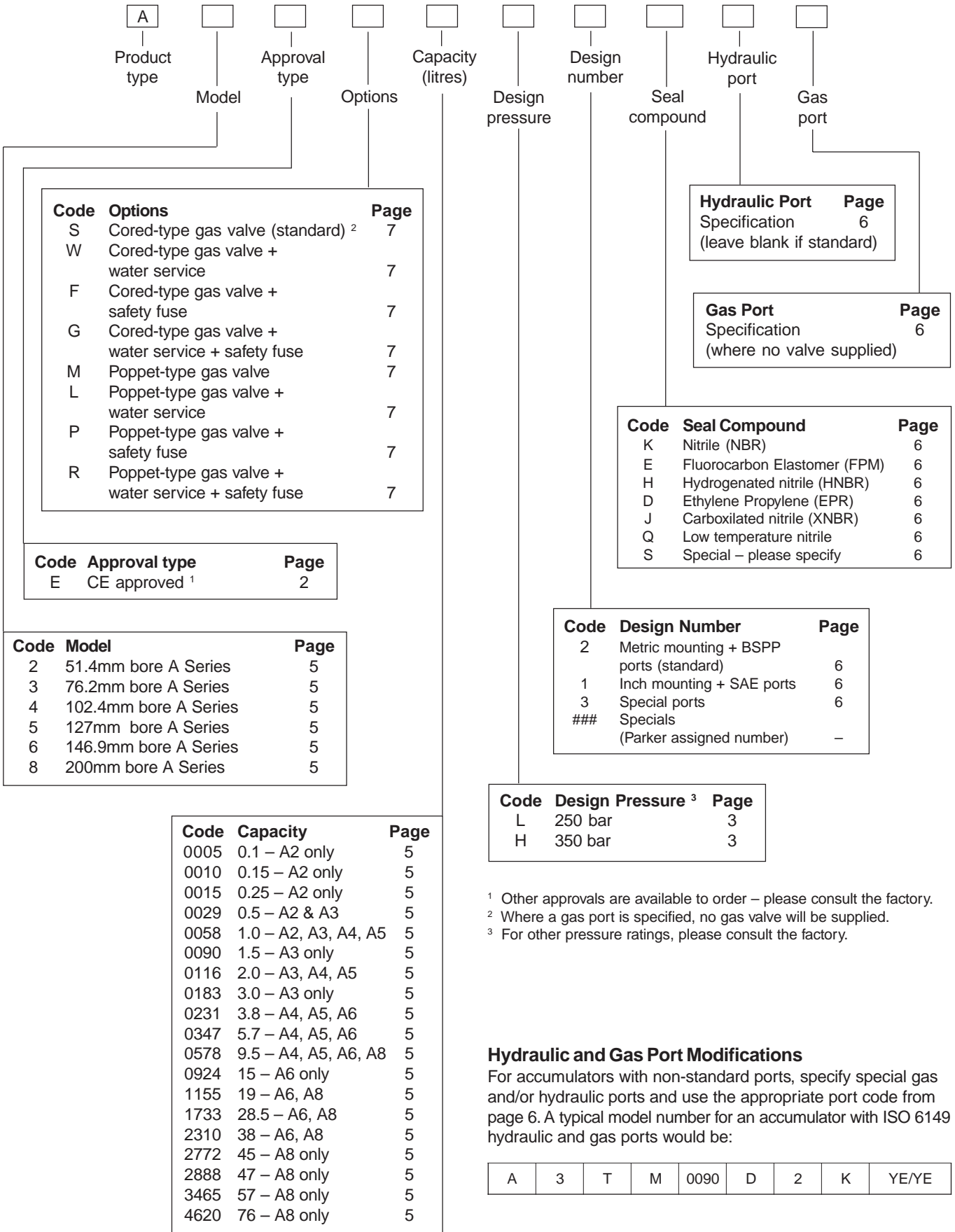

¹ Other approvals are available to order – please consult the factory.

² Where a gas port is specified, no gas valve will be supplied.

³ For other pressure ratings, please consult the factory.

Hydraulics Group Sales Offices

Europe

Austria

Wiener Neustadt
Tel: +43 (0)2622 23501
Fax: +43 (0)2622 66212

Belgium

Nivelles
Tel: +32 (0)67 280 900
Fax: +32 (0)67 280 999

Czech Republic

Prague
Tel: +420 2 830 85 221
Fax: +420 2 830 85 360

Denmark

Ballerup
Tel: +45 4356 0400
Fax: +45 4373 8431

Finland

Vantaa
Tel: +358 (0)9 4767 31
Fax: +358 (0)9 4767 3200

France

Contamine-sur-Arve
Tel: +33 (0)450 25 80 25
Fax: +33 (0)450 03 67 37

Germany

Kaarst
Tel: +49 (0)2131 4016 0
Fax: +49 (0)2131 4016 9199

Hungary

Budapest
Tel: +36 (06)1 220 4155
Fax: +36 (06)1 422 1525

Ireland

Dublin
Tel: +353 (0)1 293 9999
Fax: +353 (0)1 293 9900

Italy

Corsico (MI)
Tel: +39 02 45 19 21
Fax: +39 02 4 47 93 40

The Netherlands

Oldenzaal
Tel: +31 (0)541 585000
Fax: +31 (0)541 585459

Norway

Ski
Tel: +47 64 91 10 00
Fax: +47 64 91 10 90

Poland

Warsaw
Tel: +48 (0)22 863 49 42
Fax: +48 (0)22 863 49 44

Portugal

Leca da Palmeira
Tel: +351 22 9997 360
Fax: +351 22 9961 527

Slovakia

Ref. Czech Republic

Spain

Madrid
Tel: +34 91 675 73 00
Fax: +34 91 675 77 11

Sweden

Spånga
Tel: +46 (0)8 597 950 00
Fax: +46 (0)8 597 951 10

United Kingdom

Warwick
Tel: +44 (0)1926 317 878
Fax: +44 (0)1926 317 855

International

Australia

Castle Hill
Tel: +61 (0)2-9634 7777
Fax: +61 (0)2-9899 6184

Canada

Milton, Ontario
Tel: +1 905-693-3000
Fax: +1 905-876-0788

China

Beijing
Tel: +86 10 6561 0520
Fax: +86 10 6561 0526

Asia Pacific Group

Hong Kong, Kowloon
Tel: +852 2428 8008
Fax: +852 2425 6896

India

Mumbai
Tel: +91 22 7907081
Fax: +91 22 7907080

Japan

Tokyo
Tel: +(81) 3 6408 3900
Fax: +(81) 3 5449 7201

Latin America Group

Brazil
Tel: +55 12 3954-5100
Fax: +55 12 3954-5266

South Africa

Kempton Park
Tel: +27 (0)11-961 0700
Fax: +27 (0)11-392 7213

USA

Cleveland (industrial)
Tel: +1 216-896-3000
Fax: +1 216-896-4031
Lincolnshire (mobile)
Tel: +1 847-821-1500
Fax: +1 847-821-7600

Parker Hannifin is the world's premier supplier of motion and control systems and solutions, with sales and manufacturing facilities throughout the world. For product information and details of your nearest Parker sales office, visit us at www.parker.com or call free on 00800 2727 5374.



Catalogue HY07-1240/5-UK
2M 10/04

© Copyright 2004
Parker Hannifin Corporation
All rights reserved.